

IX2-DSU unit



BX-DSU unit



IX2-DSU, BX-DSU specifications

Confocal Scan Method	Disc rotation method
Maximum scan speed	Image acquisition less than 33msec/frame
Camera	Recommended camera: CoolSNAP HQ, Orca ER
Excitation wavelength	350nm - 700nm. Wavelengths of less than 430nm at naked eye observation and DSU observation may reduce the confocal effects.
Fluorescence wavelength at observation	At less than 450nm, use our HQ filter for observation
Observation mode	Exchange between confocal and non-confocal modes can be performed through the software
ND filter for excitation	An ND filter will be inserted automatically at the exchange of confocal and non-confocal modes
Electromagnetic shutter for excitation	Can be controlled through the software
Microscope attachment	Intermediate attachment method (other cameras can be mounted on C-mount intermediate attachment)
Temperature and humidity	10°C - 35°C, 30 - 80%
Power	Provided through microscope controller

Dimensions

(unit: mm)

IX2-DSU dimensions

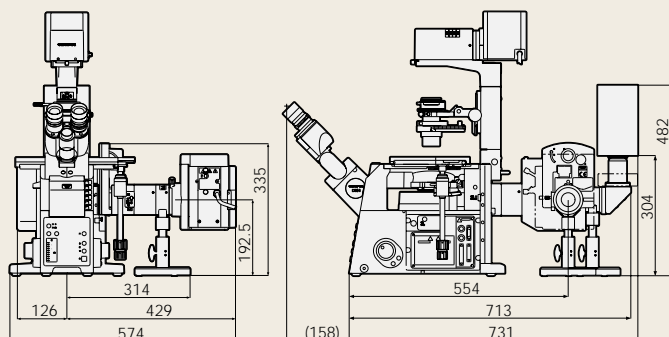

Weight: approximately 50kg / Power consumption: approximately. 1.5kW

BX-DSU dimensions

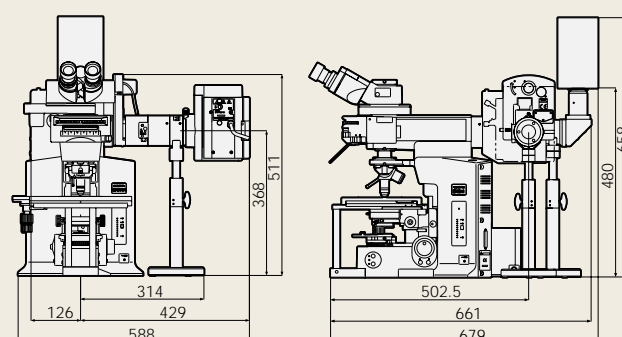

Weight: approximately. 50kg / Power consumption: approximately. 1.5kW

*All brands are trademarks or registered trademarks of their respective owners.

Specifications are subject to change without any obligation on the part of the manufacturer.



OLYMPUS

OLYMPUS CORPORATION
Shinjuku Monolith, 3-1, Nishi Shinjuku 2-chome, Shinjuku-ku, Tokyo, Japan
OLYMPUS EUROPA GMBH
Postfach 10 49 08, 20034, Hamburg, Germany
OLYMPUS AMERICA INC.
Two Corporate Center Drive, Melville, NY 11747-3157, U.S.A.
OLYMPUS SINGAPORE PTE LTD.
491B River Valley Road, #12-01/04 Valley Point Office Tower, Singapore 248373

OLYMPUS UK LTD.
2-8 Honduras Street, London EC1Y 0TX, United Kingdom.
OLYMPUS AUSTRALIA PTY. LTD.
31 Gilby Road, Mt. Waverley, VIC 3149, Melbourne, Australia.
OLYMPUS LATIN AMERICA, INC.
6100 Blue Lagoon Drive, Suite 390 Miami, FL 33126-2087, U.S.A.

www.olympus.com

OLYMPUS[®]

Your Vision, Our Future

BIOLOGICAL DISC SCANNING MICROSCOPE

IX2-DSU/BX-DSU

Live-Cell Confocal Microscopy



UIS
UNIVERSAL
INFINITY SYSTEM

Comparing 2-D images of cellular microtubule fragments taken with the DSU (Disc Scan Unit) versus standard, widefield fluorescence

Images from the same section of PtK2 cell microtubule fragments: Image on the left was acquired using the DSU confocal and the image on the right was acquired using standard, widefield fluorescence.

Note the excellent confocal effects of the DSU including the excellent optical sectioning and removal of out of focus light especially with thicker specimens.

Photos courtesy of:

OLYMPUS CORPORATION Scientific Equipment Division

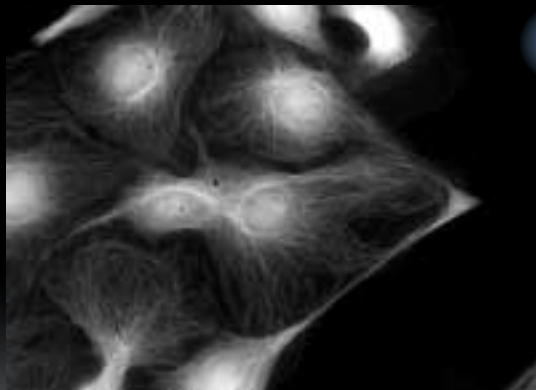

DSU live-cell confocal

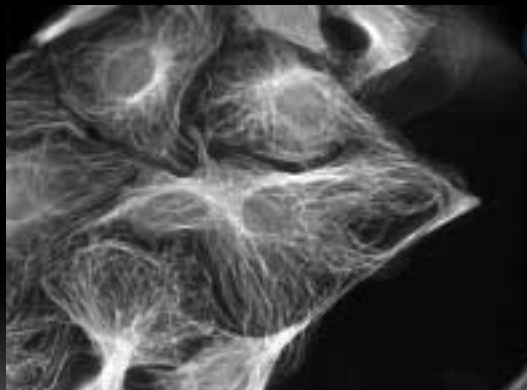

Standard Widefield Fluorescence

Confocal image a cooled C

■ Acquiring confocal images using a cooled CCD camera

In conventional fluorescence microscopy the inside structure of a thick specimen cannot be observed clearly because of the significant contribution of out of focus light from above and below the focal plane. The disc scan unit makes it possible to reject this out of focus light by placing a rotating, slit disc in a confocal plane of the microscope. The result is a clear, continuous, optically cross-sectioned image that can be imaged up to 30 f/p/s with a cooled CCD camera. Every image acquired by the camera has the DSU confocal effect alleviating the need for post image processing, thus improving data reliability for 3-D images.

*See specifications to find which CCD cameras are recommended.

■ Principles of Operation

Fluorescence excitation light from a white light source (xenon or mercury lamp) is first filtered for the required wavelength and then reflected via a dichromatic mirror. This reflected light passes through a unique, spinning slit confocal disc, (which is located in a conjugate position to the objective's focal plane), through the objective and focused onto the specimen. Emitted fluorescence light from the specimen is then collected by the objective and sent back through the confocal disc. The passing of focused light back through the disc produces the required confocal effects. Fluorescence emission light is then selected for wavelength by a filter and focused on a cooled CCD camera to form visible images.

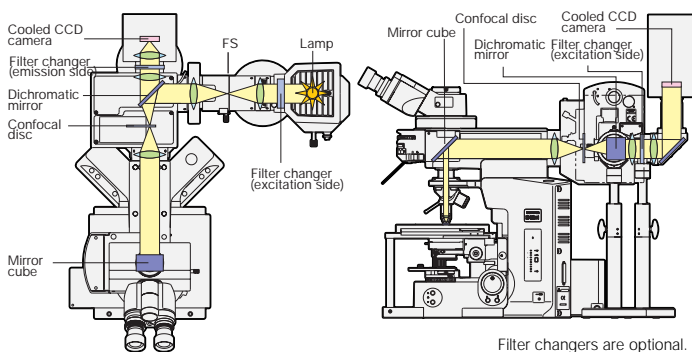

■ Excellent cost-performance

By utilizing white light sources, the DSU is more cost effective than laser based systems. You can use the white light source (xenon or mercury lamp) you already own, without modification. As your needs change, you can easily update the fluorescence excitation characteristics by adding new filter and dichromatic mirror sets to coincide with your new fluorochromes. A laser based system often requires a new laser source for a new fluorochromes.

The DSU system also supports DAPI excitation in the near UV without modification. Filter-mirror sets for GFP and DsRED are included.

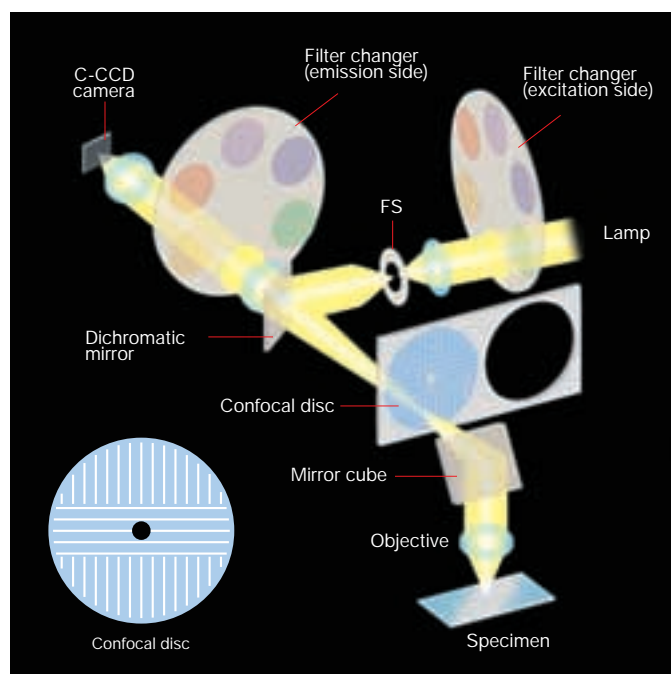

3-D extended focus image of fruit fly brain

3-D extended focus image obtained from a 230µm thick specimen via 70 discrete z-sections at 2µm increments.

Objective: UPlanApo20X

Photo courtesy of:

Prof. Kei Ito

Dr. Takeshi Awasaki

Department of Molecular Biology

Tokyo University

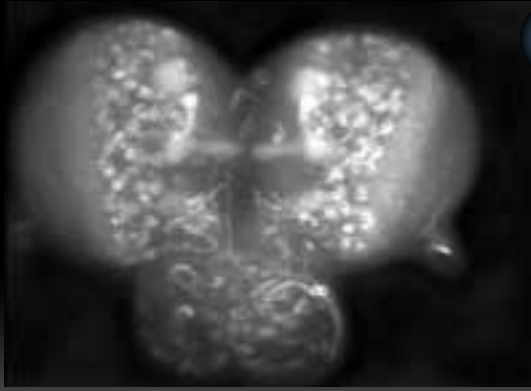

3-D extended focus image

3-D image of swallowtail butterfly visual central nerves

3-D image obtained from a 300µm thick specimen via 90 discrete z-sections at 2µm increments.

Objective: UPlanApo20X

Photo courtesy of:

Mitsuyo Kinoshita, Prof. Kentaro Arikawa

Laboratory of Neuroethology, Graduate School of Integrated Science
Yokohama City University

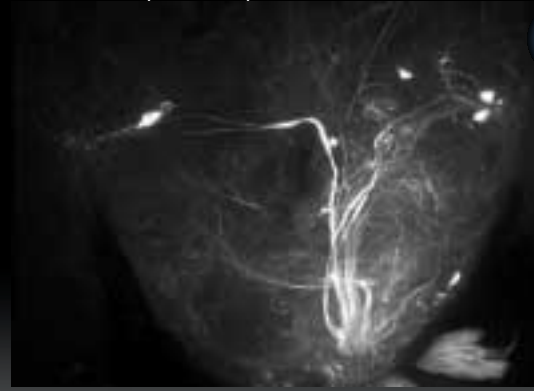

DSU 3-D image

observation with CD camera

■ Easy operation

A simple hand switch close to the operator's hand makes it easy to control such operations as inserting/removing the confocal disc into the light path, exchanging cubes and opening/closing the shutter. It is quick and easy to exchange between general fluorescence observation and confocal observation.

■ Advanced system performance

Confocal 3-D image stacks can be acquired easily using the Inverted IX81 or Upright BX61 microscope platforms with their built-in, precise Z motor. Image acquisition software can be used to control microscope, DSU and digital camera for a very easy to use complete solution to your imaging needs.

■ A choice of discs for different purposes

Five different types of discs are available, with different slit widths to suit different objectives and specimen thicknesses.

Exchanging one disc for another is easy using the provided tools. In the case of the BX61WI, the best confocal effect is obtained by selecting the appropriate disc to suit the objective in use.



IX2-DSU



BX-DSU